

## YO'L FREZASI KONSTRUKSIYASINING TAHLILI

**Mahammadjonov Nurmuhammad Abdurahob o'g'li<sup>1</sup>**

Assistent,

<sup>1</sup>Andijon Mashinasozlik Instituti, Andijon shahar O'zbekiston

**Meliqo'ziyev Abdulaziz Rasuljon o'g'li<sup>2</sup>**

Assistent,

<sup>2</sup>Andijon Mashinasozlik Instituti, Andijon shahar O'zbekiston

**Badriddinov Omadjon Xusniddin o'g'li<sup>3</sup>**

Talaba,

<sup>3</sup>Andijon Mashinasozlik Instituti, Andijon shahar O'zbekiston

**Abdulxamidov Saidamir Abdunabi o'g'li<sup>4</sup>**

Talaba,

<sup>4</sup>Andijon Mashinasozlik Instituti, Andijon shahar O'zbekiston

**G'anijonov Muhammadaziz G'ayratjon o'g'li<sup>5</sup>**

Talaba,

<sup>5</sup>Andijon Mashinasozlik Instituti, Andijon shahar O'zbekiston

<https://doi.org/10.5281/zenodo.7264986>

Yo'l frezasi bu - asfalt-beton, sement-beton yoki boshqa yo'l qoplamasini qavatma-qavat olib tashlash, shuningdek frezalangan materialni (asfalt parchalarini, tuproq va boshqalarni) bog'lovchi va yoki boshqa komponentlar bilan aralashtirish uchun mo'ljallangan o'ziyurar, tirkamali, yarim tirkamali, o'rnatilgan yoki qo'lda ishlaydigan yo'l uskunasi hisoblanadi [1,2].

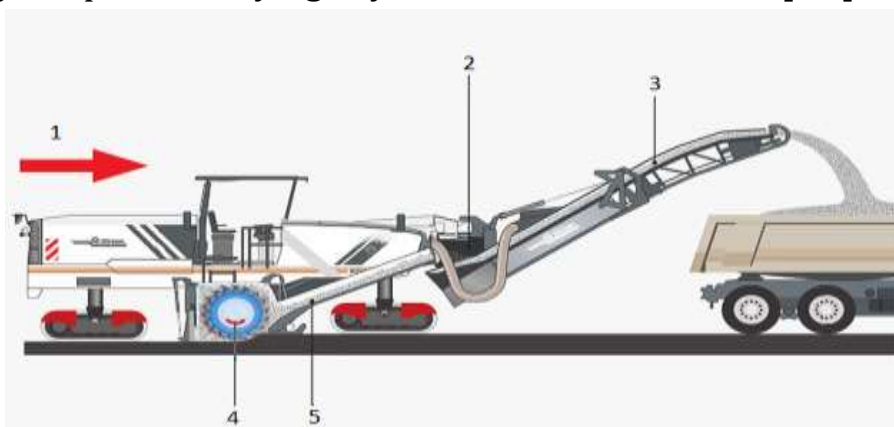

1-harakat yo'nalishi, 2-materialni konveyerning qabul qiluvchi qismidan tushirish qismiga o'tkazish, 3-konveyerning tushirish qismi, 4-yo'l frezasi barabani, 5-konveyerning qabul qiluvchi qismi.

**1-rasm. Avtomobil yo'llarini ta'mirlashda foydalaniladigan yo'l frezasining ish jarayoni ketma-ketligi.**

Ko'pgina hollarda, yo'l frezasi haqida gap ketganda, ular yo'llar va yo'l uchastkalarini asfalt-beton yoki sement-beton qoplama bilan joriy (yamoqlash) yoki kapital ta'mirlash uchun mo'ljallangan sovuq turdagi yo'l frezasini

anglatadi. Shu bilan birga, dizayni va ishlash prinsipi bo'yicha sovuq turdagi yo'l frezasiga o'xshash, ammo boshqa maqsadga ega bo'lgan yo'l qurilish uskunalari ham mavjud, xususan:

Sovuq holda qayta ishlovchi (odatda, oddiygina "qayta ishlab chiqaruvchi") – suyuq bog'lovchi ta'minot tizimi bilan jihozlangan o'ziyurar, sovuq turdagi yo'l frezalash mashinasidir. An'anaviy yo'l frezalash mashinasidan farqli o'laroq, frezalashdan tashqari, qayta ishlovchi frezalashtirilgan materialni bog'lovchi (organik yoki mineral) va kerak bo'lganda boshqa komponentlar bilan ham aralashtiradi [3,4,5].

Tuproq stabilizatori (tuproq aralashtirgich) - suyuq bog'lovchi ta'minot tizimi bilan jihozlangan o'ziyurar yoki o'rnatilgan sovuq turdagi yo'l frezalash mashinasi va yumshatilgan tuproqni bog'lovchi (mineral yoki organik) bilan aralashtirish va aralashtirish uchun mo'ljallangan [6,7].

Issiq holda qayta ishlovchi (termoprofiler) - asosiy komponentlaridan biri asfalt-beton yo'l qoplamalarini issiq frezalash, frezalangan materialni bog'lovchi va yoki boshqa komponentlar bilan aralashtirish va qayta ishlash, asfaltlash (issiq regeneratsiyalangan aralashmani yotqizish) uchun mo'ljallangan "issiq" turdagi yo'l qurilish majmuasi [8,9,10,11].

Yo'l frezalash mashinasining tuzilishi va ishlash prinsipi.



### 1.7-rasm. Yo'l frezasi qismlari.

Yo'l frezerining asosiy ishchi organi frezalash barabani bo'lib, uning yuzasida asbob ushlagichlari bo'lgan qattiq qotishmali kesgichlar joylashtirilgan.

Qattiq qotishmali frezaning dizayni va ishlash prinsipi.

Zamonaviy sovuq turdagi yo'l frezasi quyidagi tarkibiy qismlardan iborat:

Tish kallagi – Zo'riqishda ishlaydigan qismi. Tish kallagining xizmat qilish muddatini uzaytirish maqsadida, uning uchiga volfram karbid va kobaltdan iborat qattiq qotishma kavsharlanadi. Birinchi komponent (volfram karbid) tish kallagining qattiqqligini va yeyilishbardoshligini ta'minlaydi, ikkinchisi (nisbatan



yumshoq kobalt) volfram karbid donalarini bog'lab, yuqori zarb kuchlanishlari ostida yuqori bikrlikni ta'minlaydi [12,13,14,15].

Kavshar – freza tishini kesgich korpusi bilan birlashtiruvchi element hisoblanib, qattiq qotishmali tish kallagini kavsharlash yo'li bilan po'lat kesgich korpusini bog'laydi [16,17,18,19].

Kesgichning korpusi – kesgichning po'lat korpusi, sovuq presslash usuli bilan tayyorlangan. Kesgich korpusi kesuvchining kallagi va dastasidan tashkil topgan. Kesuvchining kallagi yuqori kesish va zarba kuchlariga bardosh berishi uchun mo'ljallangan va dastaning vazifasi - kesgichni asbob ushlagichida ishonchli mahkam ushlab turish [5,6].

Yeyilishbardoshli shayba – qattiq qotishmali po'latdan yasalgan kesgich elementi bo'lib, uning o'qi atrofida kesuvchining optimal aylanishini ta'minlaydi. Qisish gilzasi – silindrsimon element bo'lib, kesgich dastagini ushlab turadi va uning aylanishini, aniq joylashishini va asbob ushlagichida ishonchli mahkamlanishini ta'minlaydi [1,3,9].

Yo'l qoplamasini frezalash jarayonida freza o'zining bo'ylama o'qi atrofida harakat qiladi. Bunday holda, aylanish asosan frezalash paytida emas, balki bo'sh turganda sodir bo'ladi. Ushbu aylanishning natijasi kesgichning qoplamaga tegib turgan yuzalarida yeyilish jarayoni sodir bo'ladi, bu esa o'z navbatida frezalash sifati va samaradorligiga ta'sir qiladi [10,11].

Yo'l frezasining sifati frezalash jarayonida hal qiluvchi rol o'ynaydi, shuning uchun kesgichlar va asboblarning ushlagichlarining holatini muntazam ravishda kuzatib borish va yuqori darajada eskirish bo'lsa, ularni o'z vaqtida almashtirish kerak. Bunday nazoratning chastotasi ko'plab omillarga bog'liq va sinov frezasi bilan aniqlanadi. Masalan, 20°C havo haroratida va yaxshi sug'orish tizimida umumiy maydoni 6 m<sup>2</sup> bo'lgan nozik taneli asfalt-betondan 50 mm chuqurlikdagi asfalt qoplamasini frezalash jarayonida taxminan bitta kesgich iste'mol qilinadi [17,19,20].

Kesgichlarning tezligi va eskirish darajasi va shunga mos ravishda yo'l frezalash mashinasining unumdorligi quyidagi asosiy omillar bilan belgilanadi:

Yo'l frezasining xarakteristikalarini va parametrlari: frezalash barabanining kengligi va diametri, kesgichlarning oralig'i, kesuvchilarning hujum burchagi, kesgich ushlagichlarining eskirish darajasi, kesgich uchining shakli, frezaning aylanish tezligi, frezalash barabani, frezalash chuqurligi va boshqalar.

#### Foydalanilgan adabiyotlar:

[1] Икромов Н. А., Гиясидинов А. Ш., Рузиматов Б. Р. У. Меры по снижению экологического воздействия автопарка //Universum: технические науки. – 2021. – №. 4-1 (85). – С. 44-47.



- [2] Bakirov, L., Mamasoliyev, B., Usmonov, U., Ismailov, S., & Muxtorov, R. Z. (2022). GUARANTEE SAFE MOVEMENT BY DESIGNING DRIVER'S WORK MODE THROUGH VEHICLE KEY IN ORGANIZING INTERNATIONAL TRANSPORTATION.
- [3] Mamasoliyev B. et al. ELIMINATION OF NOISY OPERATION OF DAMAS REAR SUSPENSIONS //Science and innovation in the education system. – 2022. – Т. 1. – №. 4. – С. 59-63.
- [4] Беккулов Б. Р., Рахмонкулов Т. Б. Исследования движения шала в сушильном барабане //НАУКА РОССИИ: ЦЕЛИ И ЗАДАЧИ. – 2021. – С. 88-92.
- [5] Nurdinov M., Erkinjonov A. ANALYSIS OF THE GROWTH OF EXISTING TRANSIT ROUTES IN THE REPUBLIC OF UZBEKISTAN AND THE DUPLICATION OF HIGHWAYS IN TRANSIT ROUTES. – 2022.
- [6] Рузиматов М.А., Махмудов Ш.Ф. Улучшение экологии и охраны окружающей среды (на примере Республики Узбекистан) // Universum: технические науки : электрон. научн. журн. 2021. 5(86). URL: <https://7universum.com/ru/tech/archive/item/11702>
- [7] Nozimbek A. et al. IMPROVEMENT OF PHYSICAL AND MECHANICAL PROPERTIES OF PLASTIC PARTS USED IN MACHINE BUILDING //Universum: технические науки. – 2021. – №. 3-4 (84). – С. 52-55.
- [8] To'yuchiyev X., Soliyev B. Prospects for the use of polymeric materials in machine parts //Asian Journal of Multidimensional Research. – 2022. – Т. 11. – №. 5. – С. 151-156.
- [9] Melikuziev A. et al. IMPROVING THE PERFORMANCE OF THE FUEL INJECTION SYSTEM //Development and innovations in science. – 2022. – Т. 1. – №. 14. – С. 10-14.
- [10] Нурдинов М. и др. БЕЗОПАСНЫЕ ПАРКОВОЧНЫЕ МЕСТА ДЛЯ МЕЖДУНАРОДНЫХ ГРУЗОВИКОВ МЕТОД УПРАВЛЕНИЯ НА ТРАНЗИТНЫХ ДОРОГАХ //Models and methods in modern science. – 2022. – Т. 1. – №. 15. – С. 148-157.
- [11] Икромов Н. А. ИССЛЕДОВАНИЯ ФИЗИКО-МЕХАНИЧЕСКИХ СВОЙСТВ РАДИАЦИОННО МОДИФИЦИРОВАННЫХ ЭПОКСИДНЫХ КОМПОЗИЦИЙ И ПОКРЫТИЙ НА ИХ ОСНОВЕ //Главный редактор: Ахметов Сайранбек Махсутович, д-р техн. наук; Заместитель главного редактора: Ахмеднабиев Расул Магомедович, канд. техн. наук; Члены редакционной коллегии. – 2021. – С. 59.
- [12] Imomkulov K. B., Mukimova D. K. The motivation parameters of wedge-shaped disk of the machine for preparing plow by flap to sowing //Scientific-technical journal. – 2018. – Т. 1. – №. 3. – С. 145-147



- [13] Igamberdiev, A. K., Muqimova, D. K., Usmanov, E. Z., & Usmanova, S. D. (2022). Influence of the thickness of the roller discs of the combined machine on the indicators of their work during the processing of plowed lands afterwards. In IOP Conference Series: Earth and Environmental Science (Vol. 954, No. 1, p. 012001). IOP Publishing.
- [14] Turaev S. The role of polymer materials used in the development of automobile industry //Asian Journal of Multidimensional Research. – 2022. – T. 11. – №. 5. – C. 284-288.
- [15] Shukurov M. M. et al. Roads, road lines and thermoplastic products used in their drawing //ACADEMICIA: An International Multidisciplinary Research Journal. – 2021. – T. 11. – №. 4. – C. 258-263.
- [16] Kholmatov U. THE POSSIBILITY OF APPLYING THE THEORY OF ADAPTIVE IDENTIFICATION TO AUTOMATE MULTI-CONNECTED OBJECTS //The American Journal of Engineering and Technology. – 2022. – T. 4. – №. 03. – C. 31-38.
- [17] Kholmiraev J., Kuchkorov I., Kakhkharov A. DETERMINING THE NEED FOR SPARE PARTS FOR SPECIAL VEHICLES OPERATING AT AIRPORTS //Central Asian Academic Journal of Scientific Research. – 2022. – T. 2. – №. 5. – C. 208-211.
- [18] Baxtiyorjon o'g'li E. A. AVTOMOBIL SHINASINI CAD/CAE TIZIMLARIDA MODELLASHTIRISH. – 2022.
- [19] D. Zokirov, G. Ismoilova TRASSANING SUVGA TO'YINGAN UCHASTKALARIDA YOTQIZILADIGAN YER OSTI QUVURO'TKAZGICHLARINI HISOBLASH // SAI. 2022. №A6. URL: <https://cyberleninka.ru/article/n/trassaning-suvga-to-yingan-uchastkalarida-yotqiziladigan-yer-osti-quvuro-tkazgichlarini-hisoblash> (дата обращения: 14.10.2022).
- [20] Erkinjonov A. et al. OPERATING CONDITIONS OF TRANSPORT VEHICLES //Theoretical aspects in the formation of pedagogical sciences. – 2022. – T. 1. – №. 4. – C. 32-33.

