

DESIGN OF A MODERN FASTENING AND LOOSENING DEVICE FOR MACHINING OF PLATE-TYPE PARTS ON A MILLING MACHINE

No'monov Nodirjon Farxodjon ugli¹, Karimov Rustam

Jaxongir ugli²

^{1,2}Fergana Polytechnic Institute, Republic of Uzbekistan

<https://doi.org/10.5281/zenodo.5766304>

ARTICLE INFO

Received: 01st December 2021

Accepted: 05th December 2021

Online: 08th December 2021

KEY WORDS

technology, allowance, cutting parameters, tolerance, base plate.

ABSTRACT

In the course of the study, an analysis of the manufacturability of the part was carried out. The type of production was determined in accordance with the annual production program and the design of the part. In accordance with the type of production, as well as the material of the part, a blank was selected. Calculations of allowances, tolerances, technological dimensions, cutting modes, main and auxiliary times, work piece clamping force for milling have been carried out.

As a result of the study, a technological process for manufacturing a part was designed and a special device for milling was designed.

A device for fixing parts of the "plate" type when processing their inner contour on a milling or slotting machine, containing a body on which there are supporting base plates for installing the frame to be processed, as well as side clamps designed to fix the frame along its lateral surfaces, characterized in that that it is equipped with side and end stops installed on the body, designed to press the side and end surfaces of the frame to them, respectively, by pressing mechanisms, and the mechanism for pressing the side surface of the frame to the side stop is made in the form of a clamp installed at the end of a screw screwed into a threaded hole a strap fixed to the body, and the mechanism for pressing the end surface of the frame to the

stop is made in the form of a body installed in the bore with the possibility of reciprocating movement and rotation of the stuck, spring-loaded relative to the body and fastened with a threaded rod installed in the body, onto the threaded part which a clamping nut is screwed on, while each of the side clamps is made in the form of an L-shaped grip, mounted in the bore of the body with the possibility of reciprocating movement and rotation, and is spring-loaded relative to the body, and in each clamp there is an axial hole through which a threaded rod is passed, one threaded end of which is screwed into the body, and on the other there is screwed a clamping nut in contact with the clamp.

The article relates to the field of tooling for metal-cutting machines and can be used to fix a wide range of parts of the "frame" type when processing them on milling and slotting machines.

Parts of the "plate" type refer to planar parts, the inner contour of which is formed by one or more cavities (windows) communicating with each other or made separately. Details of the "frame" type are generally characterized by a square, rectangular or elongated shape, a wide range of sizes and varying rigidity. When processing the inner contour of such parts, it is necessary to accurately install and fix them, as well as to exclude their deformation and displacement of the position of the part in the fixture during its clamping, this is especially important for parts of significant sizes, even minor deformation and displacement of which relative to the base elements when fixing them leads to significant processing errors. The internal contours of such parts are usually machined on milling machines, and the radius surfaces of the mating of linear contours are machined on slotting machines. Therefore, it is important, when installing parts in a fixture, to arrange the fixture's clamping elements in such a way as to ensure that the inner contour can be machined with a minimum number of part reinstallations. The surface of the inner contour can be perpendicular to its planes, or made at a different angle to them.

Fig.1. Design of a modern fastening and loosening device for machining of plate-type parts on a milling machine.

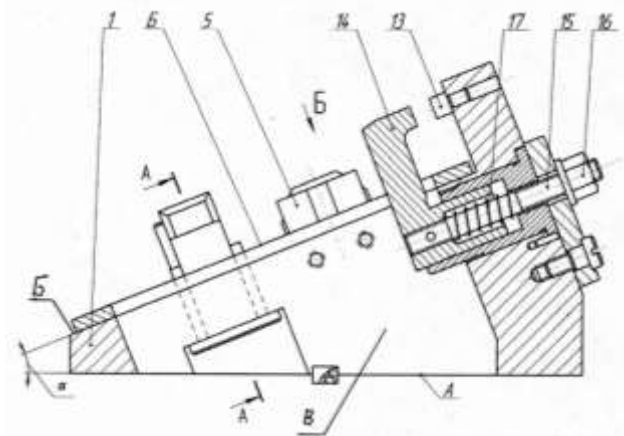

It is known an adaptation to a milling machine for fixing a part, comprising a body on which support strips are fixed, designed to install the part to be processed and move it to a predetermined position to the stop installed on the body, as well as a mechanism for securing the part, made in the form of two racks fixed to the body, on which pressure levers are mounted on the axles, connected by means of rods with a drive for their rotation to fix (unfasten) the part.

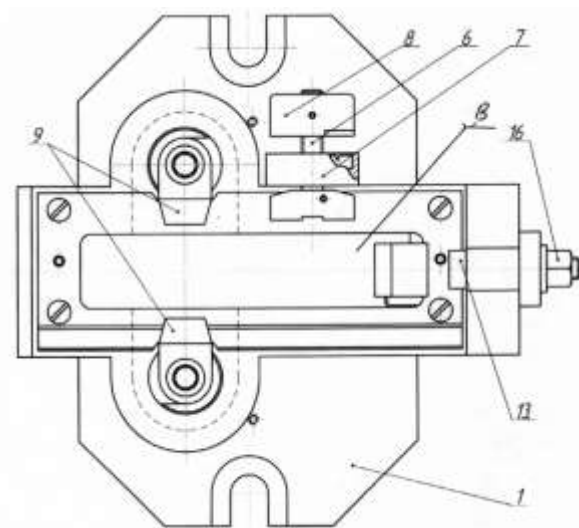

Fig.2. Design of a modern fastening and loosening device for machining of plate-type parts on a milling machine (horizontal view).



As a result of the analysis of the known device, it should be noted that its disadvantage is that the coordinated movement of the clamping levers requires high accuracy of their dimensions, because even a small different magnitude of their stroke can lead to displacement of the part when it is fastened, and, consequently, to a decrease in the accuracy of processing the part.

A device for fastening parts is known, comprising a housing, in parallel bores of which bushings are fixed. In the bushings with the possibility of axial reciprocating movement and rotation, there are rotary clamping L-shaped levers spring-loaded relative to the body, on which there are clamping elements. The ends of the L-shaped levers are connected to the rocker arm. The device is equipped with a mechanism for fixing the part with L-shaped levers, made in the form of a plunger, in which there is a groove for installing a roller, which is mounted on an axis with the possibility of rotation.

As a result of the analysis of the known device, it should be noted that it, like the claimed device, is intended for fixing flat parts. The fixation of the part in the device is carried out by clamps along the upper plane of the part to the base surface of the body without the use of mounting stops, which does not allow it to be oriented to a precisely specified position. In addition, when clamping a work piece, it may be displaced relative to the position set during installation due to the contact of the clamps with the surface of the work piece to be processed. All this reduces the accuracy of the part machining.

The technical result of this utility model is the development of a device that secures flat-shaped parts - frames with their fixation in a precisely specified position, which increases the accuracy of processing their inner contour.

References:

1. Karimov, R. (2021). PLANNING OF BELT BRIDGE FOR UNSYMMETRICAL PROGRESSIVE STAMPING. *Scientific progress*, 2(2), 616-623.
2. Karimov, R. J. O. G. L., & Toxtasinov, R. D. O. (2021). FEATURES OF CHIP FORMATION DURING PROCESSING OF POLYMER COMPOSITE MATERIALS. *Scientific progress*, 2(6), 1481-1487.
3. Karimov, R. J. O. G. L., O'G'Li, S. S. D., & Oxunjonov, Z. N. (2021). CUTTING HARD POLYMER COMPOSITE MATERIALS. *Scientific progress*, 2(6), 1488-1493.
4. Jaxongir o'g'li, R. K., & Sobirovna, N. S. IMPROVING THE QUALITY OF LASER CUTTING OF METALS BY OPTIMIZING THE TECHNOLOGICAL PARAMETERS OF THE PROCESS.
5. Rustam Karimov Jaxongir ugli, & Karimov Ravshan Xikmatullaevich. (2021). DESIGN OF DIES WITH SPLIT DIES. *EURASIAN JOURNAL OF SOCIAL SCIENCES, PHILOSOPHY AND CULTURE*, 1(3), 35-39.
6. Rustam Karimov Jaxongir o'g'li, Abullayeva Dona Toshmatovna, Rustamova Muxlisa Muxtoraliyevna, & Toxirov Islom Xakimjon o'g'li. (2021). PROGRESSIVE CONSTRUCTIONS OF ADJUSTABLE SHEET PUNCHING STAMPS. *EURASIAN JOURNAL OF SOCIAL SCIENCES, PHILOSOPHY AND CULTURE*, 1(2), 46-53.



- I. O. Ergashev, R. J. Karimov, A. M. Turg'unbekov, & S. S. Nurmatova (2021). Arrali jin mashinasidagi kolosnik panjarasi bo'yicha olib borilgan ilmiy tadqiqotlar tahlili. *Scientific progress*, 2(3), 78-82
7. Ilhom Olimjonovich Ergashev, Rustam Jaxongir o'g'li Karimov, Ravshan Xikmatullayevich Karimov, & Salimaxon Sobirovna Nurmatova (2021). Kolosnik almashinuvchi mashinasi elementi egilishining nazariy tadqiqotlari. *Scientific progress*, 2(3), 83-87
8. Rustam Karimov Jaxongir ugli, & Polotov Karimjon Quranboevich. (2021). IMPROVE THE EFFICIENCY OF TURNING LIGHT ALLOYS. *EURASIAN JOURNAL OF MATHEMATICAL THEORY AND COMPUTER SCIENCES*, 1(3), 26-30.
9. Rustam Karimov Jaxongir ugli, & Jumaev Nizomiddin Kenjaboy ugli. (2021). COMBINED METHOD OF TURNING BILLS FROM POLYMER MATERIALS. *EURASIAN JOURNAL OF MEDICAL AND NATURAL SCIENCES*, 1(3), 1-6.
10. Rustam Karimov Jaxongir o'g'li, & Polotov Karimjon Quranbaevich. (2021). PROGRESSIV SHTAMPLASH KONSTRUKSIYALARINI REJALASHTIRISH. PLANNING OF PROGRESSIVE STAMPING CONSTRUCTIONS. *EURASIAN JOURNAL OF LAW, FINANCE AND APPLIED SCIENCES*, 1(3), 10-18.
11. Турсуналиев Исломжон Дилшоджон ўғли, & Рустам Каримов Джахонгир ўғли. (2021). ПОВЫШЕНИЕ КАЧЕСТВА КОНТАКТНОЙ СТЫКОВОЙ СВАРКЕ ПРИ МАССОВОМ ПРОИЗВОДСТВЕ В АВТОМОБИЛЬНОЙ ПРОМЫШЛЕННОСТИ. *EURASIAN JOURNAL OF SOCIAL SCIENCES, PHILOSOPHY AND CULTURE*, 1(3), 91-97. <https://doi.org/10.5281/zenodo.5752576>
12. Abdumajidxon Murodxon O'G'Li Muxtorov, & Axmadbek Maxmudbek O'G'Li Turg'Unbekov (2021). VAKUUM XALQALARI UCHUN SILIKON MATERIALLARNI TURLARI VA ULARNING TAHLILI. *Scientific progress*, 2 (6), 1503-1508.
13. Ахмадбек Махмудбек Ўғли Турғунбеков (2021). НОТЕХНОЛОГИК ЮЗАНИНГ ТЕШИКЛАРИГА ИШЛОВ БЕРИШДА ДОРНАЛАШ УСУЛИНИ ТАДБИҚ ЭТИШ. *Scientific progress*, 2 (1), 4-10.
14. Ravshan, K., & Nizomiddin, J. (2020). Increasing efficiency of production of machine parts using a combined blade tool. *ACADEMICIA: An International Multidisciplinary Research Journal*, 10(5), 445-448.
15. Zulfiya, B., Rakhmonali, S., & Murodjon, K. (2021). A BRIEF HISTORY OF THE DEVELOPMENT AND TEACHING OF DRAWING SCIENCE IN UZBEKISTAN.
16. Арзиев, С. С., & Тохиров, И. Х. Ў. (2021). ФАЗОВИЙ ФИКРЛАШНИНГ БЎЛАЖАК МУҲАНДИС ВА АРХИТЕКТОРЛАР ИЖОДИЙ ФАОЛИЯТИДА ТУТГАН ЎРНИ. *Scientific progress*, 2(2), 438-442.
17. Kholmurzaev, A. A., & Polotov, K. K. (2020). METHODS OF USING MEDIA EDUCATION IN THE LEARNING PROCESS. *Theoretical & Applied Science*, (5), 205-208.
18. Tokhirov, Islombek Khakimjon Ugli (2021). SELECTION OF THE MANUFACTURING PROCESS OF THE PART. *Oriental renaissance: Innovative, educational, natural and social sciences*, 1 (10), 698-704.
19. Mamajonovich, K. A., Eraliyevna, T. Z., & Mukhtaraliyevna, R. M. (2020). Box curve (curl) of fan casing. *ACADEMICIA: An International Multidisciplinary Research Journal*, 10(5), 604-607.



20. Turdialiyev, M., Shodimatova, S., & Rustamova, M. (2021, March). SPIRITUALITY AND ENLIGHTENMENT FOUNDATION FOR THE FUTURE OF HUMANITY. In Конференции.
21. Arziyev, S. (2021). ADVANTAGES OF USING THREE-DIMENSIONAL VISUAL VIEWS IN TEACHING THE SUBJECT «DESCRIPTIVE GEOMETRY». Збірник наукових праць SCIENTIA.
22. Усманов, Д. А., Парпиев, А. П., & Холмурзаев, А. А. (2020). Очиститель хлопка-сырца от мелкого сора. Проблемы современной науки и образования, (1 (146)).
23. Мадаминов, Ж. (2021). Бўлажак муҳандисларни лойиҳалаш компетенцияларини компьютер графикаси воситасида ривожлантириш методикасини такомиллаштириш. Общество и инновации, 2(8/S), 462-469.
24. Madaminov, J. (2021). THE ACTUAL PROBLEMS AND SOLUTIONS OF THE DEVELOPMENT OF ENGINEERING DESIGN COMPETENCIES. Збірник наукових праць SCIENTIA.
25. Холмурзаев, А. А., Мадаминов, Ж. З., Рахмонов, Д. М., & Расулжонов, И. Р. (2019). Методика развития профессиональной компетентности информационно-технических средств будущих учителей черчения. Актуальная наука, (4), 112-115.
26. Dostonbek, V., & Salimaxon, N. (2021). The effect of scraping and surface cleaning on the scraping of scraping to be dressing in the cutting of polymer materials. ACADEMICIA: An International Multidisciplinary Research Journal, 11(6), 717-721.