



## ORGANIZATION OF THE PRODUCTION OF SOFT FEED FOR FISH FARMS GROWN IN LOCAL CONDITIONS

<sup>1</sup>J.Z. Xazratqulov

<sup>2</sup>F.E. Raxmatov.

<sup>1</sup>Gulistan State University

<sup>2</sup>Yangiyer branch of the Tashkent Institute of Chemical Technologies.

<https://www.doi.org/10.5281/zenodo.10374020>

### ARTICLE INFO

Received: 06<sup>th</sup> December 2023

Accepted: 13<sup>th</sup> December 2023

Online: 14<sup>th</sup> December 2023

### KEY WORDS

Fisheries, meat, hay, silage, ingredients, bone meal, vegetable, fish meal cereals (oats, barley, corn), complete rations, premixes, protein vitamin supplements, milk replacers depressants.

### ABSTRACT

*One of the main requirements of today is the use of the most modern advanced technology and equipment. On the basis of established recipes through rational processing of various raw materials coming to the enterprise production of high-quality mixed fodder products.*

*In this regard, a lot of scientific work is being carried out in our republic to create a strong feed base, which is an important factor in the development of fisheries. Omixta consists in increasing the productivity of feed products by using nutritional additives and mineral substances. A lot of innovations are being created regarding the radical renewal of the production of mixed fodder products and the production of mixed fodder that replaces imports.*

In accordance with the decision of the President of the Republic of Uzbekistan dated March 18, 2019 "On measures to further develop and support the livestock industry" No.

Stable supply of meat, milk, eggs and other livestock products in the domestic consumer market, expansion of livestock, poultry and fishery feed base, increase of production of competitive products in domestic and foreign markets and provision of high-quality mixed fodder to ensure the implementation of the decision to improve and create favorable conditions for increasing their production.

"On the measures to organize the production of fodder in the republic in a modern industrial way" of the President of the Republic of Uzbekistan "Strategy of actions on the five priority directions of the development of the Republic of Uzbekistan in 2017-2021

The production of mixed fodder prepared locally as a substitute for imports remains one of the urgent problems of today, in particular, the supply of fish and fish products to the consumer market is considered one of the urgent tasks.

The production of mixed fodder in our country is increasing year by year. Its range is expanding and its biological effectiveness is increasing. The development of the mixed fodder industry into a developed industry indicates that the use of mixed fodder is of great economic importance.

Plant and animal products, as well as mineral substances are feed for farm animals. In animal husbandry, feed is divided into coarse, liquid, concentrated, mineral and various production wastes depending on their origin, consistency and nutritional value.

One of the main requirements of today is the rational processing of various raw materials (food, sugar, starch, molasses, alcohol, beer, meat and fish industry waste) coming to the enterprise using the most modern advanced technology and equipment. production of high-quality mixed fodder products based on established recipes.

Protein-vitamin additives and mineral substances that increase the nutritional value of the mixed feed product help to increase the productivity of animals. Further development of animal husbandry on an industrial basis requires improving not only the quantity, but also the quality of the feed base created on farms.

In order to obtain a good income from fisheries, livestock and poultry farms, to increase the interests of farms and the population, the system of providing high-quality liquid feed and juicy feed for fish farms should be fundamentally improved, advanced science and technology in the technological processes of liquid feed production achievements and the need to use modern technologies, increase the quality of products, create new forms of enrichment, and ensure the high level of development of fish farms.

Taking this into account, the prepared components are transferred to special dosing machines-dispensers. According to the principle of operation, there are two methods of dosing:

In the industry, several different modifications of plate-shaped dosers are produced: for dosing DDT-various components; DT, MTD-3 – for minerals; For dosing DTK, DD-vitamins, trace elements and supplements.

Other types of volume dispensers (screw, tape, vibrating) are also used in the mixed feed industry. Dosers in each battery are designed for a certain group of components that have the same fluidity by volume and the same indicator by other physical properties.

Dish-shaped dispenser

1st receiving hopper; 2-thrower; 3-movable tray; 4th disc; 5-spade; 6-fold tray;

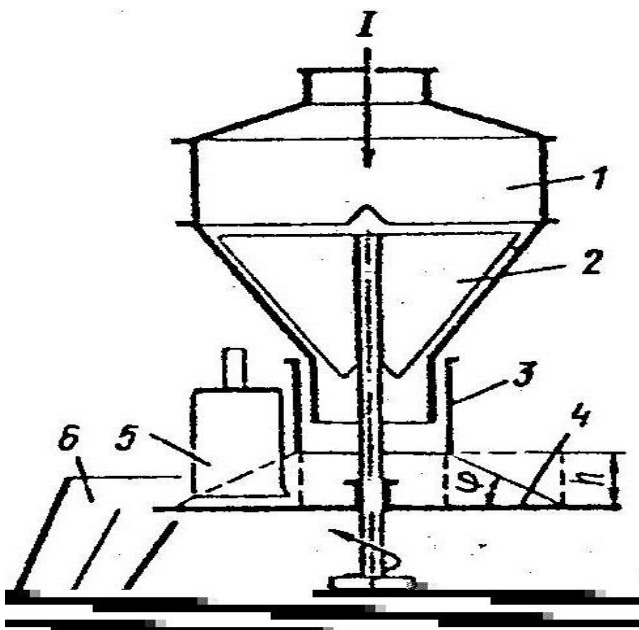

Introduction of I-product; Output of product II.

If the components included in the mixed feed are the same, 2-3 dispensers can be used to dose it. When the dispensers work, it is necessary to ensure that the product falls evenly and continuously. For this, it is necessary to control that there is always a supply of prepared raw materials in the bunkers above the dispenser and that it does not stick to the bunkers. Volume dispensers should be monitored at least 2 times per shift, and the results should be recorded in a special journal.



The following technological lines are used in the production process of mixed feed and protein-vitamin supplements:

cereal raw materials; separation of oat and barley hulls; flour raw materials; loose hay flour; pressed and large pieces of raw materials; feed products of the food industry; shot; processing of raw materials; preparation of salt; preparation of chalk and other raw materials of mineral origin; initial mixture of hard-to-disperse components; preparation of the initial mixture of cereals and other raw materials that require grinding; introduction of liquid components, urea and urea concentrates; introduction of premixes or preparation and introduction of enrichment mixtures;

Dosing of mixed feed components; mixing mixed feed and feed components; mixed fodder and feed granulation; finished product transfer.

Evaluation of the nutritional value of mixed fodder and the digestibility of mixed fodder is determined based on special experiments performed on animals.

The digestion process is different in different fish. Therefore, different types of fish digest the same mixed feed differently. The nutritional value of each mixed feed is characterized by the final result of feeding, i.e. productivity.

The nutritional value of mixed fodder and feed products is a nutritional unit and it is equivalent to the nutritional value of 1 kg of oats with a moisture content of 13% and a volumetric weight of 450-480 g/m<sup>3</sup>. Taking into account the importance of protein in animal feed, the wet protein content indicator is used in the evaluation of feed products along with the feed unit.

In the assessment of mixed feed, the number of feed units is taken in relation to 100 kg of mixed feed, and the amount of wet protein is expressed as a percentage. The nutritional value of feed for fish is estimated by the amount of exchangeable energy expressed in kilocalories per 100 g of feed.

**Conclusion:** Types of mixed feed and used raw materials, receiving, placing, storing and transferring raw materials to production, theoretical bases of preparing mixed feed components for processing, cleaning raw materials from impurities, theoretical bases of grinding mixed feed components and grinding laws, standardization and mixing in dispensers, the theoretical foundations of consolidation and compaction are covered.

The process of adding liquid components to mixed feed and granulation, technological lines and equipment for the production of mixed feed are described. The main stages of the production of protein-vitamin supplements, premixes, urea concentrates and the conditions of their effective use are considered.

## References:

1. Бобоев С.Д. ва б. "Омихта ем ишлаб чиқариш" Тошкент. 2004 й.
2. Khamdamov, M. B., Tukhtamishova, G. Q., & Ganijonov, D. I. (2023). Influence of the Degree of Grain Damage by the Bug Turtle on Its Bakery Properties. *Journal of Advanced Zoology*, 44(S2), 1984-1988.
3. Solijonov, G. K., Uzaydullaev, A. O., Kuzibekov, S. K., & Jankorazov, A. M. (2023). SANPIN RULES AND METHODS OF FOOD WASTE ANALYSIS. *Евразийский журнал академических исследований*, 3(11), 52-56.



4. Barakaev, N. R., & Kuzibekov, S. K. (2022). INVESTIGATION OF FLOW HYDRODYNAMICS IN THE PROCESS OF ASPIRATION CLEANING OF SOYBEAN SEEDS (GRAIN) ON A COMPUTER MODEL. *Harvard Educational and Scientific Review*, 2(2).
5. Rajabovich, B. N., Nusratillayevich, R. A., Tashpulatovich, K. M., & Komilovich, K. S. (2020). Improvement of the design of mobile equipment for post-harvest processing of agricultural crops. *Journal of critical reviews*, 7(14), 306-309.
6. Barakaev, N. R., Kurbanov, J. M., Uzaydullaev, A. O., & Gafforov, A. X. (2021, September). Qualitative purification of pomegranate juice using electro flotation. In *IOP Conference Series: Earth and Environmental Science* (Vol. 848, No. 1, p. 012024). IOP Publishing.
7. Nurmuxamedov, A., & Jankorazov, A. (2023). ANALYSIS OF THE METHODS OF IMPROVING THE FRYING PROCESS IN THE PRODUCTION OF VEGETABLE OILS. *Science and innovation*, 2(A1), 266-271.
8. Sattorov, K. K., & Nurmammedov, A. A. (2021). Jankorazov. AM, Choriev KR "Features of Triglycerides Isomerization in the Process of Hydrogenization of Cottonseed Oils" *International Journal of Disaster Recovery and Business Continuity*, 12(1), 990-997.
9. Nurmuxamedov, A., & Jankorazov, A. (2023). METHODS OF IMPROVING THE FRYING PROCESS IN THE PRODUCTION OF SOY OIL. *Евразийский журнал академических исследований*, 3(4 Part 4), 41-48.
10. Hamdamov, M., Jankorazov, A., Hazratqulov, J., & Xidirova, S. (2023). STRUCTURE OF PROTEINS AND APPLICATION IN THE FIELD OF BIOTECHNOLOGY. *Евразийский журнал академических исследований*, 3(4 Part 4), 212-220.
11. Jankorazov, A., Xolmamatova, D., & Murodboyeva, M. (2023). ENZYMES AND THEIR INDUSTRIAL APPLICATION METHODS. *International Bulletin of Engineering and Technology*, 3(3), 102-107.
12. Solijonov, G., Uzaydullaev, A., Kuzibekov, S., & Jankorazov, A. (2023). THE ROLE OF STANDARDIZATION IN THE INDUSTRY AND THE ANALYTICAL METHODS OF PRODUCT CERTIFICATION. *Science and innovation*, 2(A3), 144-149.
13. Javsurbek, K., Abror, J., Akhmad, N., & Shakir, I. (2023). REQUIREMENTS FOR THE QUALITY OF RAW MATERIALS PROCESSED IN THE INDUSTRY. *Universum: технические науки*, (1-4 (106)), 47-49.
14. Khazratkulov, J. Z., & Tashmuratov, A. N. (2023). STUDYING METHODS OF IMPROVING THE PROCESS OF APPLE JUICE PRODUCTION. *International Bulletin of Engineering and Technology*, 3(4), 38-42.
15. Karshievich, S. K., & Uli, K. J. Z. (2021). Dependence of the Content of Trans-Isomerized Fatty Acids on Hydrogenate Indicators. *Central Asian Journal of Theoretical and Applied Science*, 2(10), 27-30.
16. Jankorazov, A., Saydjanova, D., & Navro'zova, I. (2023). CHEMICAL COMPOSITION OF SOY PLANT AND IMPROVING TECHNOLOGY OF OIL PROCESSING IN INDUSTRY. *Евразийский журнал академических исследований*, 3(5 Part 2), 111-11
17. Nurmukhamedov, A. A., Jankorazov, A. M., Khazratkulov, J. Z., & Tashmuratov, A. N. (2023). Methods of Improving the Frying Process in the Production of Vegetable Oils. *Journal of Advanced Zoology*, 44(S-2), 1961-1969.