



ANALYSIS OF EFFECTIVE SEED LINTER TECHNOLOGY IN COTTON GINNING ENTERPRISES

Ungarov Azizbek Abdumo'min o'g'li
Xudayberdiev Rustamjon Xasanovich
Eshmuratova Iroda Shuxrat qizi

Gulistan State University Syrdarya, Uzbekistan.
<https://doi.org/10.5281/zenodo.15124918>

ARTICLE INFO

Qabul qilindi: 25-Mart 2025 yil
Ma'qullandi: 28- Mart 2025 yil
Nashr qilindi: 31- Mart 2025 yil

KEY WORDS

Fiber, lint, technique, resource efficient, seed, technology, linter, energy.

ABSTRACT

In our republic, special attention is being paid to the introduction of modern resource-saving techniques and technologies for high-quality production of fiber and cotton products. This article talks about science-based modern techniques and technologies that improve the quality of seed and fluff

INTRODUCTION.

In the world, cotton fiber is the main raw material of the textile industry, while cotton fluff is the main raw material of the chemical and cellulose-paper industry. Particular attention is paid to the introduction of modern resource-saving techniques and technologies for the high-quality production of fiber and cotton products. Not only in foreign countries developed with the cotton sector, but also in our republic, in the linting of the seed produced from cotton processing, the technology reduces the number of linters by increasing the productivity of the linter, saves the consumption of electricity and spare parts, and ensures the ecological environment in the territory of the enterprise. , extensive research and development works are being carried out within the framework of the production and implementation of scientifically based modern techniques and technologies that improve the quality of the produced seed and fluff.

MAIN PARTS AND RESULTS

After the technological process of ginning in cotton gins, the seeds are cleaned from the weeds and transferred to the linting equipment. During the ginning process, some of the fibers present in seeded cotton are added to the seed and contaminate it. The gin seed contains coarse sand, debris, accidentally dropped metal fragments, and small stones, as well as unhealthy (damaged and immature) seed, which grinds up on screw conveyors and elevators, and becomes the dirt of the fluff being processed. increases the level. If the ginned seed is cleaned, the lint is less polluted, the saws of the linter are not damaged and their service life is extended. Therefore, the seeds are cleaned of impurities before the linter equipment. At present, USM pneumatic seed cleaner is used to clean the seed from impurities. USM model pneumatic seed cleaner has a compact structure compared to other brands, it is simple and convenient to use. The working process is as follows: the seed is fed by the collapsing conveyor of the line of linters and falls through the shovel drum into the separation chamber through the hole in the seed suction tube. When the air current lifts the seeds up, the

heavy objects fall to the bottom of the mine and are separated. Cleaned healthy seeds are lowered into barriers and a vacuum valve and taken to the required place (linter equipment) through a screw conveyor.

The main function of the linters installed in the linting department of cotton gins is to separate the fluff from the surface of the seed mechanically, that is, with saw teeth. Linters are subject to the following requirements: seed and lint should not be damaged during linting, impurities and impurities should not be added to the lint, the mechanism that controls the quality of the lint, the level of fluffiness of the seed, and the efficiency of the lint should work. In the technological process of linting, it is considered to be a semi-automatic machine that has a mechanical effect on the seed, and is considered to be a direct flow mechanism. When removing the fluff from the saw tooth, it enters the air blower from above with the help of an air chamber. Depending on the number of saws, linters are called 160 saws. During the linter process, since the seed shaft cannot rotate under the action of the saw, in order to help it rotate, a counter-rotating device is installed in the chamber of the linters. The trimmer straightens the seed roller as it rotates, improving the arrival of hairier seeds on the saw teeth. The method of fluff separation in linters is based on the mechanical action of the saws on the rotating seed shaft, scraping the fluff from the surface of the seeds, then separating it from the saw tooth with the help of air and taking it to the condenser, where it is separated from the air. The main parameters of the linter are the amount of fluff separated from the seed and the productivity of the seed.

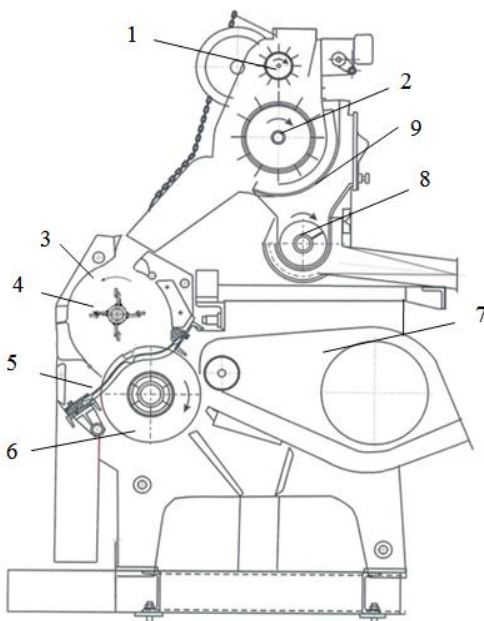

Figure 1. Schematic of the 5LP linter

1-providing roller; 2-leveling-cleaning drum; 3-existing profile working camera; 4-mixer; 5-colosnik, 6- saw cylinder; 7th air chamber; 8-waste auger; 9-mesh surface

To obtain full and high-quality fluff, a trimmer and a seed comb are involved. The main function of the trimmer is to direct the seeds in the working chamber to the teeth of the saw. The task of the seed comb is not to miss the required amount of seeds that have not been separated from the fluff. The scraped fluff passes between the saw teeth and the colosniks and is separated from the saw teeth with the help of air. The separated lint is cleaned and sent to the press. The design of linters allows the use of saws with a diameter of 320, 310, 300 and 288 mm. When installing saws of a different diameter on the linter, the position of the air

chamber and the colosnik grid must be readjusted. The gap between the saw teeth and the nozzle of the air chamber is adjusted by pushing the special screws that direct the chamber in the horizontal plane. In the following years, the improvement of the linters, the increase of its productivity, the increase of the number of saws on the saw shaft, the increase of the size of the working chamber, the improvement of the quality and quantity of fluff and seed. Having learned the secret, work was carried out in the direction of developing the speed procedures of the chainsaw cylinder and adjuster. It is determined that the saw that rotates under the influence of the linear speed adjuster and the saw teeth is under the influence of the periodic saw cylinder teeth. Saw teeth affect the seed mainly in three places:

- near the saw comb, at the place where the saw enters the working chamber, the saw changes its direction of movement by touching the saw teeth and moves in the direction of the teeth movement. At this time, due to low density, fluff is partially scraped from the surface of the seed;

- the seeds are in a dense state when they pass between the trimmer and saw teeth. At this time, the main fluff is scraped off;

- when the saw is passing between the colosniks.

CONCLUSIONS AND SUGGESTIONS.

The working chamber of the machine has a great influence on the linting process. In modern 5LP linters, the linear speed of the saws in the saw cylinder is 12.3 m/s, and the linear speed of the trimmer blades is 4.2 m/s. Based on this, it can be considered that the saw teeth affect the seed mass with a speed of 8.1 m/s. As a result of the impact of the saw on the seed at such a high speed and the impact of the trimmer on the seed roller, the seeds are damaged in the process of scraping the fluff from the surface of the seed. If the density of the seed bed is low, the adjusting blades cannot exert pressure on the seed. In this case, the effectiveness of fluff scraping decreases, and at the same time, the damage of the seed increases as a result of a lot of mechanical impact.

List of references:

1. Rakhmatov, O., Tukhtamishev, S. S., Khudoiberdiev, R. K., Adilov, A. A., & Rahmatov, F. O. (2023, April). Experimental and theoretical studies of the modulus of elasticity and Poisson's ratio for vegetable and melon crops. In International Conference on Digital Transformation: Informatics, Economics, and Education (DTIEE2023) (Vol. 12637, pp. 291-297). SPIE.
2. Nuriev, K. K., Nuriev, M. K., Rakhmatov, O., Korabekova, S., & Bakhronova, M. A. (2022, December). Determination of the total resistance of the ploughshare when the blade is blunted. In IOP Conference Series: Earth and Environmental Science (Vol. 1112, No. 1, p. 012014). IOP Publishing.
3. Рахматов, О. О., Рахматов, Ф. О., & Тухтамишев, С. (2017). ЭКОНОМИЧЕСКАЯ ЭФФЕКТИВНОСТЬ ТЕХНОЛОГИЧЕСКОЙ ЛИНИИ ПО ПРОИЗВОДСТВУ ВЯЛЕННОЙ ДЫНИ. In Научно-практические пути повышения экологической устойчивости и социально-экономическое обеспечение сельскохозяйственного производства (pp. 1317-1320).
4. РАХМАТОВ, О., НУРИЕВ, К. К., & ТОШБАЕВА, Ш. К. (2014). Безотходная комплексная переработка плодов дыни. In ТЕХНИКА И ТЕХНОЛОГИИ: ПУТИ ИННОВАЦИОННОГО РАЗВИТИЯ (pp. 222-226).
5. Rakhmatov, O., & Rakhmatov, F. (2023). Experimental study of the process of drying melon slices in a chamber-convection dryer. In E3S Web of Conferences (Vol. 443, p. 02004). EDP

Sciences.

6. Tukhtamishv, S. (2023). WEIGHT-DIMENSIONAL AND VOLUMERIAN INDICATORS AND PHYSICAL AND MATHEMATICAL PROPERTIES CHARACTERISTIC FOR CENTRAL ASIAN VARIETIES OF MELONS. *Journal of Agriculture & Horticulture*, 3(11), 912.
7. Tukhtamishv, S., Xudayberdiyev, R., & Tukhtamishova, G. (2023). MECHANIZED APPARATUS FOR CUTTING MELON FRUIT INTO ANNULAR SLICES. *Science and innovation*, 2(A1), 252-255.
8. Тухтамишов, С. С., Рахматов, О. О., Янгибаева, Г., & Худайбердиев, Р. (2019). Разработка конструктивной схемы выделителя семян. In *Научные основы развития АПК: Сб. науч. тр. по материалам XXI Всерос.(нац.) научн.-практ. конф. студентов, аспирантов и молодых ученых с международным участием (19 апреля–10 июня 2019г.)–Томск-Новосибирск: ИЦ Золотой колос, 2019.–491 с. (р. 296).*
9. Рахматов, О. О., Тухтамишев, С. С., Нуриев, К. К., & Рахматов, О. (2019). Разработка мини-технологической линии по безотходной переработке плодов. In *Научные основы развития АПК (pp. 286-289).*
10. To'xtamishv, S. S. (2023). MEVA O'SIMLIKLARINING INDIVIDUAL RIVOJLANISHI. *RESEARCH AND EDUCATION*, 2(4), 51-56.
11. Нуриев, К. К., & Нуриев, М. К. (2024). ПОВЫШЕНИЕ КАЧЕСТВА ДВУХЯРУСНОЙ ВСПАШКИ ПУТЕМ УЛУЧШЕНИЯ ПАРАМЕТРОВ ДОЛОТА ЛЕМЕХА. *Экономика и социум*, (11-2 (126)), 766-773.
12. Нуриев, К. К., & Нуриев, М. К. (2022). АНАЛИТИЧЕСКИЕ ИЗУЧЕНИЕ ВЛИЯНИЯ ПАРАМЕТРОВ ИЗНОШЕННОГО ЛЕМЕХ НА ГЛУБИНУ ВСПАШКИ. *Экономика и социум*, (11-2 (102)), 590-597.
13. Катибович, Н. К. (2024). ОЦЕНКА СОСТОЯНИЯ ВЫБРАКОВАННЫХ ОБОРОТНЫХ ЛАП ЧИЗЕЛЕЙ. *Eurasian Journal of Technology and Innovation*, 2(1-1), 119-125.
14. Катибович, Н. К. (2024). ПЛУГ ЛЕМЕХИ РЕСУРСИНИ ОШИРИШНИНГ САМАРАЛИ ЕЧИМИ. *Eurasian Journal of Technology and Innovation*, 2(1-1), 126-136.
15. Катибович, Н. К. (2024). АНАЛИТИЧЕСКИЙ МЕТОД РАСЧЕТА ИЗНАШИВАНИЯ ЛЕЗВИЯ ПОЧВОРЕЖУЩИХ РАБОЧИХ ОРГАНОВ. *Eurasian Journal of Technology and Innovation*, 2(1-1), 137-143.
16. Нуриев, К. (2022). Экспериментальное определение рациональных параметров носка долота лемеха двухъярусного плуга. *Евразийский журнал академических исследований*, 2(13), 73-82.
17. O'G'Li, E. A. I., & O'G'Li, M. I. R. (2024). MEVALI DARAXTLARGA SHAKIL BERISH VA BUTASH ORQALI MAHSULDORLIKNI OSHIRISH. *Eurasian Journal of Academic Research*, 4(5-1), 43-47.
18. O'G'Li, E. A. I., & O'G'Li, M. I. R. (2024). MEVALI BOG 'LAR YERLARIGA ISHLOV BERISHVA QATOR ORALARIDAN TO 'G 'RI FOYDALANISHNING O 'ZIGA HOS XUSUSIYATLARI. *Eurasian Journal of Medical and Natural Sciences*, 4(5-1), 131-134.
19. O'G, U. A. A. M., O'G'Li, M. I. R., & O'g'li, K. B. I. (2024). BEGONA ARALASHMALARNING TOLA VA MOMIQ SIFATIGA TASIRI. *Central Asian Journal of Multidisciplinary Research and Management Studies*, 1(17), 121-123.
20. Ogli, Q. I. M., & Ogli, M. I. R. (2024). COTTON RECEIVING RULES IN COTTON MILLS AND COTTON RECEIVING PLACES. *Eurasian Journal of Academic Research*, 4(1-2), 93-96.

21. Махмудов, И. Р. Ў., & Турдибоев, А. А. Ў. (2024). ШАРОББОП УЗУМ НАВЛАРИНИ МАЙДАЛАШ ВА ПРЕСЛАШ ЖАРАЁНИ ТАСНИФИ. Central Asian Journal of Multidisciplinary Research and Management Studies, 1(8), 123-129.
22. Ungarov, A., & Xudayberdiev, R. (2023). IMPROVING INFRARED DRYING OF AGRICULTURAL PRODUCTS. Евразийский журнал академических исследований, 3(12 Part 2), 230-233.
23. O'G, U. A. A. M., & O'G, J. R. I. M. (2024). PAXTA TOZALASH KORXONALARIDA CHIGITNI SAMARALI LINTERLASH TEXNOLOGIYASI TAHLILI. Eurasian Journal of Academic Research, 4(4-1), 125-128.
24. O'G, U. A. A. M., Xasanovich, X. R., & Qizi, Y. D. X. (2024). ANALYSIS OF EFFECTIVE SEED LINTER TECHNOLOGY IN COTTON GINNING ENTERPRISES. American Journal Of Agriculture And Horticulture Innovations, 4(04), 12-15.
25. Ungarov, A., Otaboyev, M., Weizhou, Z., Xueji, Y., & Guo, F. (2025). RESEARCH ON THE EFFICIENCY OF THE DOMESTIC LINTERS WORKING CHAMBER. Инновационные исследования в современном мире: теория и практика, 4(8), 63-66.
26. Khujakulov, F., Egamberdiev, P., Julbekov, I., Abduraimov, D., & Ungarov, A. (2023). The dependence of grape feeding on the productivity indicator and harvest quality of rizamat and large dry varieties

INNOVATIVE
ACADEMY