



## CALCULATION OF THE THERMODYNAMIC CYCLE OF A VAPOR COMPRESSION HEAT PUMP INSTALLATION WITH A SUBCOOLER FOR HEATING AND HOT WATER SUPPLY.

O.S.Komilov<sup>1</sup>

S.S.Sayfulloev<sup>2</sup>

F.R. Rustamova<sup>3</sup>

(Teacher of the school № 54. Bukhara, Uzbekistan)

<sup>1-2-3</sup>Bukhara Engineering Technological Institute,  
Bukhara, Uzbekistan

<https://doi.org/10.5281/zenodo.7336606>

### ARTICLE INFO

Received: 01<sup>st</sup> November 2022

Accepted: 12<sup>th</sup> November 2022

Online: 19<sup>th</sup> November 2022

### KEY WORDS

heat pump, heating coefficient, regulating valve, evaporator temperature, condenser, low-potential heat, evaporator, refrigerant, heat conversion coefficient, throttle, compressor, entropy, supercooler.

### ABSTRACT

*This article analyzes the methodology of calculation of the thermodynamic cycle of a vapor compression heat pump installation with a subcooler for heating and hot water supply. As a result of this, the temperature change in the heat pump was analyzed and the process of hot exchange in the device was calculated. As a result of the research, the hotline change coefficient of the device was obtained.*

The thermodynamic perfection of a heat pump installation depends on the values of the absolute temperatures of the evaporator and condenser, as well as the thermodynamic characteristics of the actual cycle of the heat pump. In turn, the perfection of the real cycle is determined by the irreversibility of the process of heat transfer and the temperature difference between its source and heat sink.

Thus, the main task in calculating the circuit diagram of a heat pump installation is to take into account all these factors that affect the heat conversion coefficient of the heat pump.

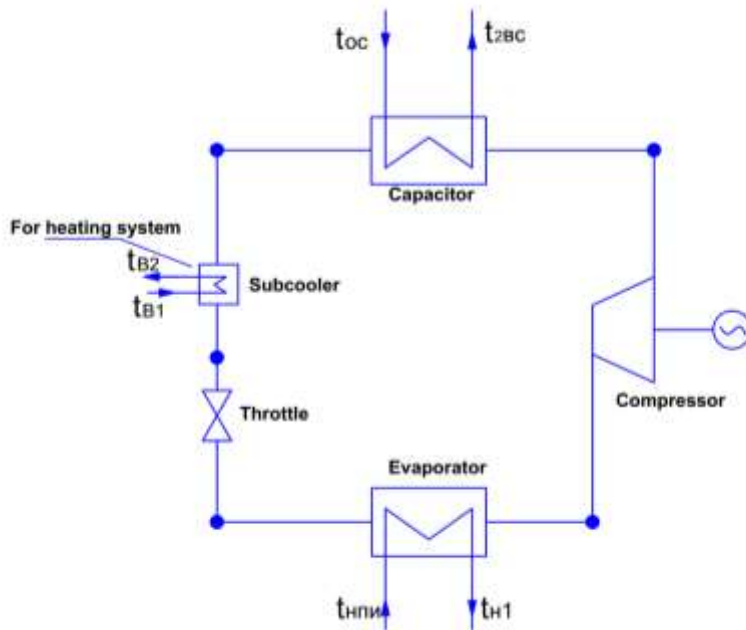

Figure 1. - Schematic diagram of a vapor compression heat pump installation with a pre-cooler.

When calculating the schematic diagram of a heat pump installation, the following sequence was drawn up:

1. Drawing up a schematic diagram of a heat pump installation. Systems of air and water heating, ventilation and air conditioning with heat pumps, as a rule, have three circuits: internal circuit - a closed circuit of the working fluid; external or primary circuit - the circuit of the NPT carrier; heating circuit - the circuit of the heat carrier of the heat consumer.
2. Choice of the working agent for the heat pump. The selection of the refrigerant is based on the temperature and pressure in the cycle. The best is the refrigerant, the critical region of which is farthest from the operating parameters, since approaching this region reduces the heat output and increases the energy consumption for compression in the compressor.
3. The main parameters of the thermodynamic cycle of the heat pump are determined. The evaporation temperature of the working fluid is taken depending on the temperature of the low-potential heat source. It should be 4-5 °C below the source temperature low-grade heat:

$$t_1 = t_u = t_{\text{HNT}} - \Delta t_u,$$

where is the temperature of the source of low-potential heat, °C;  $t_{\text{HNT}}$

$\Delta t_u$  - temperature head of the evaporator, °C;

Based on the obtained evaporation temperature, we determine the parameters:

$$P_1 = P_u = f(t_1); h_1 = h_u = f(t_1); s_1 = f(t_1).$$

The condensation temperature is taken depending on the temperature of the low-potential heat source. If the coolant is water, then it is 3-5°C higher than the HCV temperature, and if air, then by 5...10°C.

$$t_1 = t_k = t_{\text{nc}} + \Delta t_k,$$

where is the temperature of the direct network, °C;  $t_{\text{nc}}$

$\Delta t_k$  - temperature difference of the condenser, °C;

According to the condensation temperature on the left boundary curve at point "3", we determine the parameters:  $P_3 = f(t_k); h_3 = f(t_k)$ .

We determine the enthalpy at the end of adiabatic compression:  $h_{2a} = f(P_3; s_1)$ .

Real entropy at point "2":  $h_2 = h_1 - \frac{h_{2a} - h_1}{\eta_{2a}}$ . Point "2" is determined by the value of the actual enthalpy at the end of the compression process and the condensation pressure of the working fluid.

In the HPI scheme with a subcooler, it is necessary to determine the parameters of the working fluid after the subcooler (point "3\*"). According to the given temperature difference in the subcooler at the outlet of it, the following condition must be met:  $\Delta t_{ne}$

$$\Delta t_{ne} = t_{3^*} - t_{B^2},$$

where is the temperature of the refrigerant after the precooler, °C;  $t_{3^*}$

$t_{B^2}$  - coolant temperature after the precooler, °C.

The heat balance of the subcooler has the following form:

$$c_{p^3}(t_K - t_{3^*}) = c_B(t_{B^2} - t_{B^1}),$$

where is the heat capacity of the refrigerant at points "3", the heat capacity of water  $c_{p^3}, c_B$  respectively, kJ/kg K;

$t_K$  - condensation temperature, °C;

$t_{3^*}$  - temperature of the refrigerant after the pre-cooler, °C;

$t_{B^2}$  - coolant temperature after precooler, °C;

$t_{B^1}$  - coolant temperature at the subcooler inlet, °C.

The temperature of the working fluid after the subcooler is determined in the following way:

$$t_{3^*} = \frac{c_{p^3} \cdot t_K + c_B(\Delta t_{ne} - t_{B^1})}{c_{p^3} + c_B},$$

where is the heat capacity of the refrigerant at points "3", the heat capacity of water, respectively, kJ / kgK;  $c_{p^3}, c_B$

$\Delta t_{ne}$  - temperature head of the subcooler, °C;

$t_K$  - condensation temperature, °C;

$t_{B^1}$  - coolant temperature at the subcooler inlet, °C.

Enthalpy of the working fluid after the subcooler:  $h_{3^*} = f(t_{3^*}; P_K)$ .

Enthalpy at the inlet to the evaporator:  $h_4 = h_{3^*}$

#### 1. Thermal balance of the condenser:

$$G_{xл} \cdot (h_{\text{BX,КОН}}^{xл} - h_{\text{ВЫХ,КОН}}^{xл}) = G_{\text{CB}} \cdot C_p \cdot (t_{\text{П}} - t_{\text{О}}) = Q_{\text{TH}},$$

where - the consumption of freon and network water, respectively, kg / s;  $G_{xл}; G_{\text{CB}}$

$h_{\text{BX,КОН}}^{xл}; h_{\text{ВЫХ,КОН}}^{xл}$  - freon enthalpy at the inlet and outlet of the condenser, respectively, kJ/kg;

$C_p$  - heat capacity of water, kJ/kgK;

$t_{\text{П}}; t_{\text{О}}$  - temperature of the direct and return networks, °C;

$Q_{\text{TH}}$  - thermal power of the heat pump, kW.

#### 1.1 Finding the refrigerant flow:

$$G_{xл} = \frac{Q_{\text{TH}}}{(h_{\text{BX,КОН}}^{xл} - h_{\text{ВЫХ,КОН}}^{xл})},$$

where is the enthalpy of freon at the inlet and outlet of the condenser, respectively, kJ / kg;  $h_{\text{BX,КОН}}^{xл}; h_{\text{ВЫХ,КОН}}^{xл}$

$Q_{\text{TH}}$  - thermal power of the heat pump, kW.

#### 1.2 Find the consumption of network water:

$$G_{CB} = \frac{Q_{TH}}{C_p \cdot (t_{nc} - t_{oc})},$$

$C_p$  - heat capacity of water, kJ/kgK;

$t_{nc}$ ;  $t_{oc}$  - temperature of the direct and return networks, °C;

$Q_{TH}$  - thermal power of the heat pump, kW.

2. Heat balance of the subcooler:

$$G_{xл} \cdot (h_{вх,пе}^{xл} - h_{вых,пе}^{xл}) = G_{CB} \cdot C_p \cdot (t_{nc} - t_{oc}) = Q_{TH},$$

where - the consumption of freon and network water, respectively, kg / s;  $G_{xл}$ ;  $G_{CB}$

$h_{вх,пе}^{xл}$ ;  $h_{вых,пе}^{xл}$  - freon enthalpy at the inlet and outlet of the subcooler

respectively, kJ/kg;

$C_p$  - heat capacity of water, kJ/kgK;

$t_{nc}$ ;  $t_{oc}$  - temperature of the direct and return networks, °C;

$Q_{TH}$  - thermal power of the heat pump, kW.

2.1 Finding the refrigerant flow:

$$G_{xл} = \frac{Q_{TH}}{(h_{вх,пе}^{xл} - h_{вых,пе}^{xл})},$$

2.2 Total refrigerant consumption:  $G_{xл.общ} = G_{xл.гвс} + G_{xл.опт}$

3. Heat balance of the evaporator:

$$G_{xл} \cdot (h_{вых,и}^{xл} - h_{вх,и}^{xл}) = G_{нпи} \cdot C_p \cdot \Delta t,$$

where is the flow rate of freon and the flow rate of the source of low-grade heat  $G_{xл}$ ;  $G_{нпи}$  respectively, kg/s;

$h_{вых,и}^{xл}$ ,  $h_{вх,и}^{xл}$  - freon enthalpy at the inlet and outlet of the evaporator, respectively, kJ/kg;

$C_p$  - heat capacity of water, kJ/kgK;

$\Delta t$  - temperature head of the evaporator, °C;

3.1 Find the flow rate of the coolant low-grade heat:

$$G_{нпи} = \frac{G_{xл} \cdot (h_{вых,и}^{xл} - h_{кон.пр.расш}^{xл})}{C_p \cdot \Delta t},$$

where  $G_{xл}$  - freon consumption, kg/s;

$h_{вых,и}^{xл}$ ,  $h_{кон.пр.расш}^{xл}$  - freon enthalpy at the outlet of the evaporator and at the end expansion process, respectively, kJ/kg;

$C_p$  - heat capacity of water, kJ/kgK;

$\Delta t$  - temperature head of the evaporator, °C;

4. Electric power spent on the compressor drive:

$$N_3^k = \frac{G_{общ} \cdot (h_{вх,кон}^{xл} - h_{вых,и}^{xл})}{\eta_{oi}},$$

where  $G_{общ}$  - total freon consumption, kg/s;

$h_{вх,кон}^{xл}$ ,  $h_{вых,и}^{xл}$  - freon enthalpy at the outlet of the evaporator and at the end of the expansion process, respectively, kJ/kg;

$\eta_{oi}$  - indicator efficiency of the compressor.

5. Heat conversion coefficient:

$$\varphi = \frac{Q_{TH}}{N_3^k},$$

where is the thermal power of the heat pump, kW.  $Q_{TH}$   
 $N_3^k$ - Electric power spent on the compressor drive, kW.

#### References:

1. Gjengedal, S., Ramstad, R.K., Hilmo, B.O., Frengstad, B.S., 2018. Video inspection of wells in open loop ground source heat pump systems in Norway. IGSHPA Research Track, Stockholm. Oklahoma State University, Sweden. Stillwater.
2. Bakema, G., 2001. Well and Borehole Failures and Solutions in Underground Thermal Energy Storage.
3. Energy efficiencies of Heat Pumps in Residential Buildings/ I.G. Ingersoll, D.K. Arasteh // Energy and Buildings. – 1983.
4. Геотермальные тепловые насосы. Обзор рынка / Л. Милова // Тепловые насосы – 2013.
5. Ground water heat pumps – the second wave / S. Harlburt // Water Wheel Journal. – 1988.
6. Метод расчета и анализ совместной работы контура циркуляции грунтовых теплообменников и теплового насоса / С.О. Филатов, В.И. Володин // Труды БГТУ. – 2013.
7. Тепловой насос: эффективно и экономно / Л.А. Кривов, В.В. Суров // Жилищное и коммунальное хозяйство. – 1988.
8. Исследование теплонасосных систем отопления (модельный подход) / О.А. Некрасова, Ю.В. Синяк // Теплоэнергетика. – 1986.